

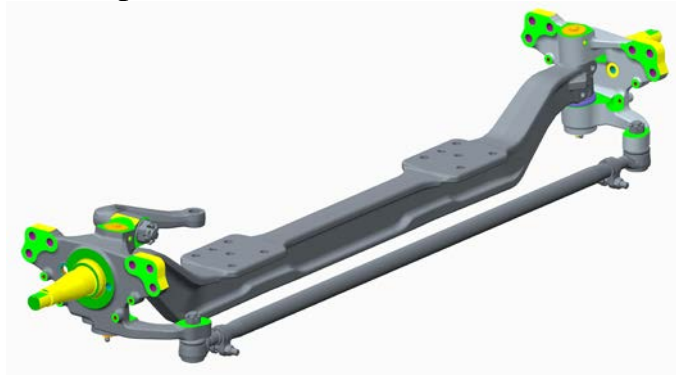

Kenworth Makes Meritor MFS+ Front Steer Axle Standard on Class 8 Trucks

KIRKLAND, Wash. – Kenworth Class 8 trucks are now standard with the lightweight, Meritor® MFS+™ front steer axle series for linehaul applications. The new axle is available in standard and wide track configurations, with a gross axle weight rating (GAWR) of 12,000 and 13,200 pounds.



**Meritor MFS+ Front Steer Axle
without Disc Brakes**

The Meritor MFS+ axle saves weight, enhances performance, and reduces service time. The new axle's optimized gooseneck beam design provides a stronger, lightweight package. The low-profile design element simplifies integration into the chassis to reduce maintenance costs.

The axle also offers high-angle turning capacity up to 55 degrees and is compatible with air disc brakes and all drum brakes. An offset knuckle, with integrated torque plate and tie rod arms, is available with air disc brake applications. It eliminates the need for separate torque plate and fasteners, saving an additional 15 pounds compared to the current air disc brake installation.

The new design also reduces space constraints for easier access by technicians. The MFS+ is designed for mounting each brake at “12-o'clock” for easy removal. Overall the MFS+ with integrated torque plates and tie rod arms may reduce weight by up to 85 lbs. – depending on brake and axle configuration – resulting in increased payloads.



**Meritor MFS+ Front Steer Axle
with Disc Brakes**

For more information, visit www.meritor.com.

Kenworth is The Driver's Truck. See what drivers are saying at www.kenworth.com/drivers.

Kenworth Truck Company is the manufacturer of The World's Best® heavy and medium duty trucks. Kenworth's Internet home page is at www.kenworth.com. Kenworth is a PACCAR company.