



2023 T680E Body builder Supplement

June 2023

PACCAR Inc.



# SECTION 1 – INTRODUCTION



## MODEL T680E

The T680E BEV (Battery Electric Vehicle) Body Builder Manual Supplement was designed to provide body builders additional information regarding the Battery Electric Vehicle option on the T680. For fundamental information not exclusive to the BEV variant, refer to the Kenworth Heavy Duty Body Builder Manual.

The T680E BEV utilizes the pre-VMUX electrical architecture; the pre-VMUX information is in the Kenworth Heavy Duty Body Builder Manual. The T680E is equipped with thermally controlled battery packs. The fully integrated, all-electric powertrain of the T680E is designed for optimal weight distribution and performance and utilizes two wheelbase configurations: 190" and 216". The 216" wheelbase is available with an ePTO for supplemental equipment powering.

In the interest of continuing product development, Kenworth reserves the right to change specifications or products at any time without prior notice. The user is responsible for ensuring they are working with the latest released information. Check [Kenworth.com](http://Kenworth.com) for the latest released version.

If you require additional information or reference materials, please contact your local Kenworth dealer.



## Table of Contents

<b>SECTION 1 – INTRODUCTION</b> .....	<b>1</b>
<b>SECTION 2 - SAFETY AND COMPLIANCE</b> .....	<b>4</b>
SAFETY SIGNALS.....	4
FEDERAL MOTOR VEHICLE SAFETY STANDARDS COMPLIANCE .....	4
INCOMPLETE VEHICLE CERTIFICATION .....	5
COMPRESSED AIR SYSTEM .....	8
COOLING SYSTEM .....	8
BATTERY ELECTRIC VEHICLE SYSTEM.....	8
<b>SECTION 3 – DIMENSIONS</b> .....	<b>11</b>
INTRODUCTION .....	11
ABBREVIATIONS.....	11
OVERALL DIMENSIONS .....	11
EXTERIOR CONFIGURATIONS.....	12
EXTERIOR DIMENSIONS .....	13
WHEELBASE CONFIGURATIONS.....	14
<b>SECTION 4 - BODY MOUNTING</b> .....	<b>16</b>
INTRODUCTION .....	16
CRITICAL CLEARANCES.....	16
<i>Tire Clearance</i> .....	16
FRAME DRILLING .....	16
BODY MOUNTING USING U-BOLTS .....	17
REAR BODY MOUNT.....	20
<b>SECTION 5 FRAME MODIFICATIONS</b> .....	<b>21</b>
<b>SECTION 6 – ELECTRICAL</b> .....	<b>22</b>
<b>SECTION 7 – ELECTRIC POWER TAKE-OFF (EPTO)</b> .....	<b>23</b>
INTRODUCTION .....	23
BATTERY ELECTRIC VEHICLE ePTO POWER SOURCE.....	23
BATTERY ELECTRIC VEHICLE ePTO.....	24
MERITOR ePTO.....	<b>ERROR! BOOKMARK NOT DEFINED.</b>
<b>APPENDIX</b> .....	<b>28</b>
VEHICLE IDENTIFICATION .....	28
<i>VIN Location</i> .....	28
<i>Chassis Number Locations</i> .....	29
VEHICLE IDENTIFICATION LABELS.....	29
TIRE AND RIM WEIGHT RATING DATA LABEL .....	29
<i>Incomplete Vehicle Certification Label</i> .....	29
<i>Components and Weights Label</i> .....	30
<i>Noise Emission Label</i> .....	30
<i>Paint Identification Label</i> .....	30
COMPONENT IDENTIFICATION .....	30



*Engine Identification*.....*Error! Bookmark not defined.*  
*Transmission Identification* ..... 30  
*Front Axle Identification* ..... 30  
*Rear Axle Identification* ..... 30

**TABLE OF FIGURES** .....**32**

**TABLE OF TABLES** .....**33**

REVISION LOG ..... 33



## SECTION 2 - SAFETY AND COMPLIANCE

### Safety Signals

There are several alerting messages in this book. Please read and follow them. They are there for your protection and information. These alerting messages can help you avoid injury to yourself or others and help prevent costly damage to the vehicle. Key symbols and “signal words” are used to indicate what kind of message is going to follow. Pay special attention to comments prefaced by “WARNING”, “CAUTION”, and “NOTE.” Please do not ignore any of these alerts.

#### **WARNING**

**Signals a potentially hazardous situation which, if not avoided, could result in death or serious injury. This message will tell you what the hazard is, what can happen if you do not heed the warning, and how to avoid it**

Example:

WARNING! Be sure to use a circuit breaker designed to meet liftgate amperage requirements. An incorrectly specified circuit breaker could result in an electrical overload or fire situation. Follow the liftgate installation instructions and use a circuit breaker with the recommended capacity

#### **CAUTION**

**Signals a potentially hazardous situation which, if not avoided, could result in minor or moderate injury or damage to the vehicle**

Example:

CAUTION: Never use a torch to make a hole in the rail. Use the appropriate drill bit

#### **NOTE**

**Provides general information that is related to the topic being discussed.**

Example:

Note: Be sure to provide maintenance access to the battery box and fuel tank fill neck.



**Signals the location of a high voltage electrical component**

Example:

HAZARDOUS VOLTAGE: To reduce the risk of possible injury (Shock, Burn or Death): Components marked with High Voltage should be avoided. Service must be performed by qualified personnel only

### Federal Motor Vehicle Safety Standards Compliance

As an Original Equipment Manufacturer (OEM), Kenworth Truck Company ensures that our products comply with all applicable U.S. or Canadian Federal Motor Vehicle Safety Standards. However, if a



vehicle has no fifth wheel and that a Body Builder (Intermediate or Final Stage Manufacturer) will be doing additional modifications means that the vehicle was incomplete when it left the build plant.

### **Incomplete Vehicle Certification**

An Incomplete Vehicle Document may be shipped with the vehicle, certifying that the vehicle is not complete. See Figure 1. In addition, affixed to the driver's side door frame or edge is an Incomplete Vehicle Certification label. See Figure 2. For further information on Vehicle Certification and Identification, see "Appendix."

**NOTE:**



These documents list the U.S. or Canadian Federal Motor Vehicle Safety Standard (FMVSS) regulations that the vehicle complied with when it left the build plant. You should be aware that if you add, modify, or alter any of the components or systems covered by these regulations, it is your responsibility as the Intermediate or Final Stage Manufacturer to ensure that the complete vehicle is in compliance with the particular regulations upon completion of the modifications.



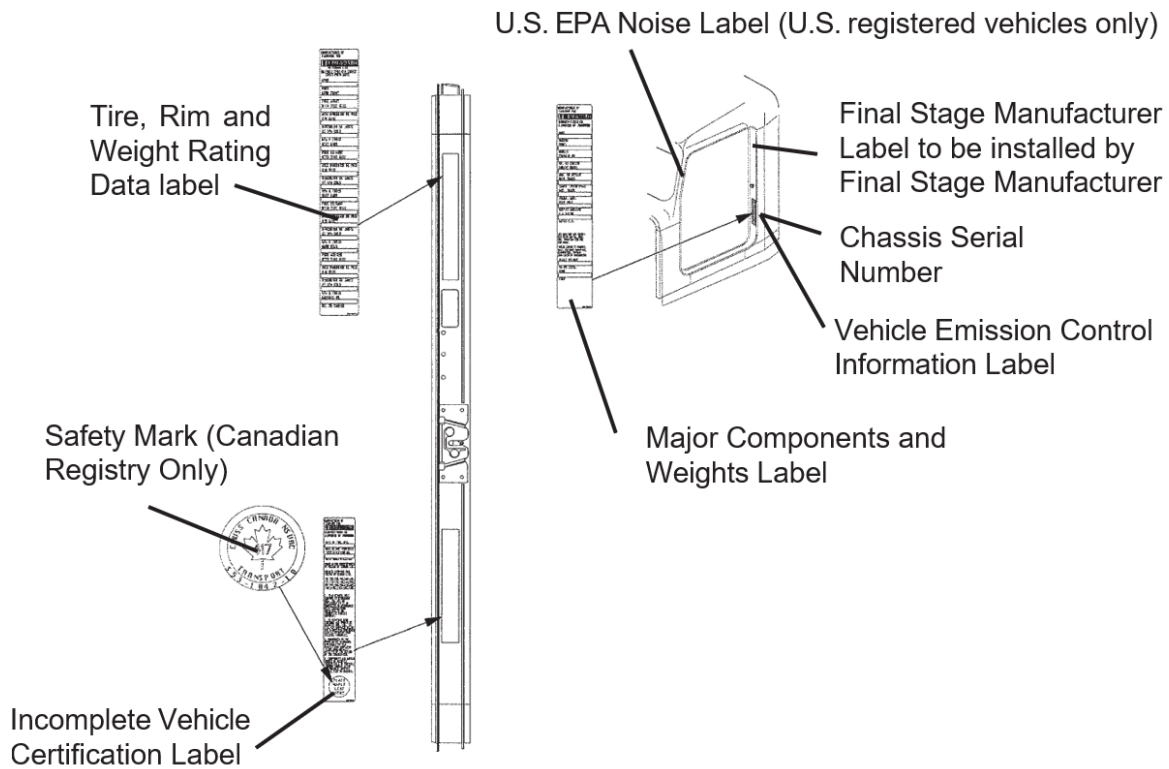

*Figure 2 Locations of Certification Labels - Driver's Door and Frame*

As the Intermediate or Final Stage Manufacturer, you should retain the Incomplete Vehicle Document for your records. In addition, you should record and retain the manufacturer and serial number of the tires on the vehicle. Upon completion of the vehicle (installation of the body and any other modifications), you should affix your certification label to the vehicle as required by Federal law. This tag identifies you as the "Intermediate or Final Stage Manufacturer" and certifies that the vehicle complies with Federal Motor Vehicle Safety Standards. (See Figure 2 Locations of Certification Labels - Driver's Door and Frame.) Be advised that regulations affecting the intermediate and final stage manufacturer may change without notice. Ensure you are referencing the most updated copy of the regulation during the certification and documentation processes.

In part, if the final stage manufacturer can complete and certify the vehicle within the instruction in the incomplete vehicle document (IVD) the certification label would need a statement that reads, "This vehicle has been completed in accordance with the prior manufacturers IVD where applicable. This vehicle conforms to all applicable Federal Motor Vehicle Safety Standards [and Bumper and Theft Prevention Standards if applicable] in effect in (month, year)."

However, if the vehicle cannot be completed and certified within the guidance provided in the IVD, the final stage manufacturer must ensure the vehicle conforms to all applicable Federal Motor Vehicle Safety Standards (FMVSS). The final stage manufactures certification label would need a statement that reads, "This vehicle conforms to all applicable Federal Motor Vehicle Safety Standards [and Bumper and Theft Prevention Standards if applicable] in effect in (month, year). These statements are





just part of the changes to the new certification regulation. Please refer to Feb 15, 2005, final rule for all the details related to this regulation. You can contact NTEA Technical Services Department at 1-800-441- NTEA for a copy of the final rule (DocID 101760).

Please refer to e-CFR Title 49: Transportation Part 567 Certification for details related to this regulation.

For Canadian final stage manufacturers see:

Motor Vehicle Safety Regulations C.R.C, c. 1038, Section 6.1 – Vehicles Manufactured in Stages

Or contact: Transport Canada  
Tower C, Place de Ville, 330 Sparks Street  
Ottawa, Ontario K1A 0N5  
(613) 990-2309  
TTY: 1-888-675-6863

## Compressed Air System

The following are highlights of some of the more common or critical aspects of this system.

- Air system modification must meet applicable FMVSS regulations
- Compressed Air tank may not be modified (exception – addition or removal of fittings or relocation of the tank)
- Added devices or bodywork may not interfere with or rub air lines
- Air lines should be routed, protected from heat, and properly secured to prevent damage from other components
- Care should be taken so that air lines do not rub against other components
- Care should be taken to protect the air system from heat sources

## Cooling System

The following are highlights of some of the more common or critical aspects of this system.

- Modifications to the design or locations of fill or vent lines, heater or defroster core, and surge tank are not recommended
- Additional accessories plumbed into the engine cooling system are not permitted, at the risk of voiding vehicle warranty
- Coolant level sensor tampering will void warranty
- When installing auxiliary equipment in front of the vehicle, or additional heat exchangers, ensure that adequate air flow is available to the vehicle cooling system. Refer to engine manufacturer application guidelines for further detail.
- See owner's manual for appropriate winter front usage

## Battery Electric Vehicle System

The following are highlights of some of the more common or critical aspects of this system.

- The Propulsion Battery Pack internals may not be modified.
- The eAxle internals may not be modified.



- The Powertrain Control Module (PCM), Propulsion Motor Inverters, Power Distribution Unit (PDU) and Supervisory Control Module (SCM) may not be modified.
- The battery chiller and coolant pumps may not be modified.
- Body Builder additional wiring should be routed, protected from heat, and properly secured to prevent damage from other components.
- High Voltage wires are orange and may not be modified.

**WARNING**

**Disconnection of the Propulsion Battery Pack fuses should only be done by personnel certified to disconnect the system.**

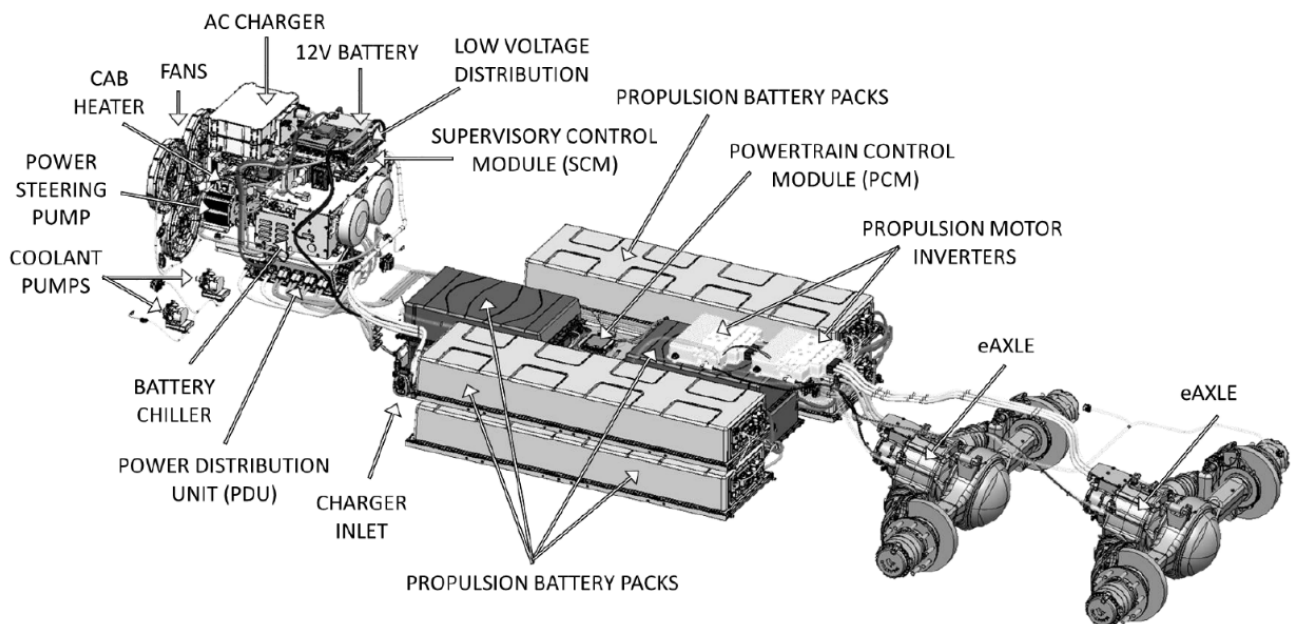

*Figure 3 Vehicle Layout*

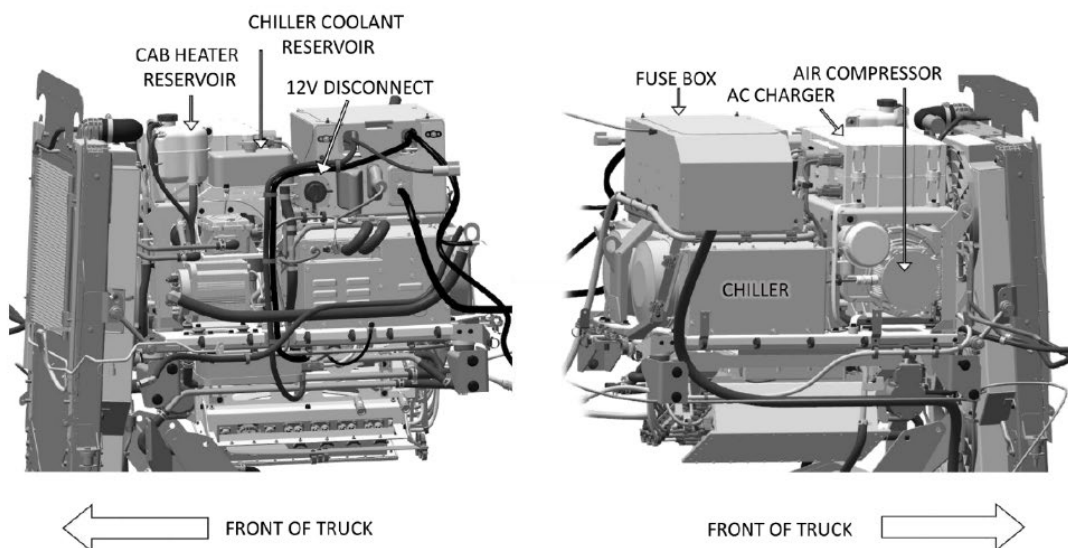

Figure 4 Additional Components on the PCAS (PCAS: Power Electronics and Controls System)



# SECTION 3 – DIMENSIONS

## INTRODUCTION

This section has been designed to provide supplemental information specific to the T680E. All dimensions are inches unless otherwise noted. Optional equipment may not be depicted. Please contact your local Kenworth dealer if more dimensional information is desired. Refer to Kenworth Heavy Duty full Body Builder Manual for additional dimensions such as interior and suspension dimensions.

## ABBREVIATIONS

Throughout this and other sections, abbreviations are used to describe certain characteristics of your vehicle. Table 3-1 below lists the abbreviated terms used.

*Table 1 Abbreviations Used*

BFA	Bumper to front axle
BOC	Back of cab
CA	Cab to axle. Measured from the back of the cab to the centerline of the rear axle(s).
EOF	End of frame
FAX	Front axle
FOF	Front of frame
WB	Wheelbase

## OVERALL DIMENSIONS

This section includes supplemental information specific to the T680E.

On the pages that follow, detail drawings show views of the vehicle; all dimensions are in inches (in). They illustrate important measurements critical to designing bodies of all types.

Kenworth also offers .dxf files and frame layouts of ordered chassis prior to build. Please speak with your local dealership to request this feature when specifying your chassis.



## EXTERIOR CONFIGURATIONS

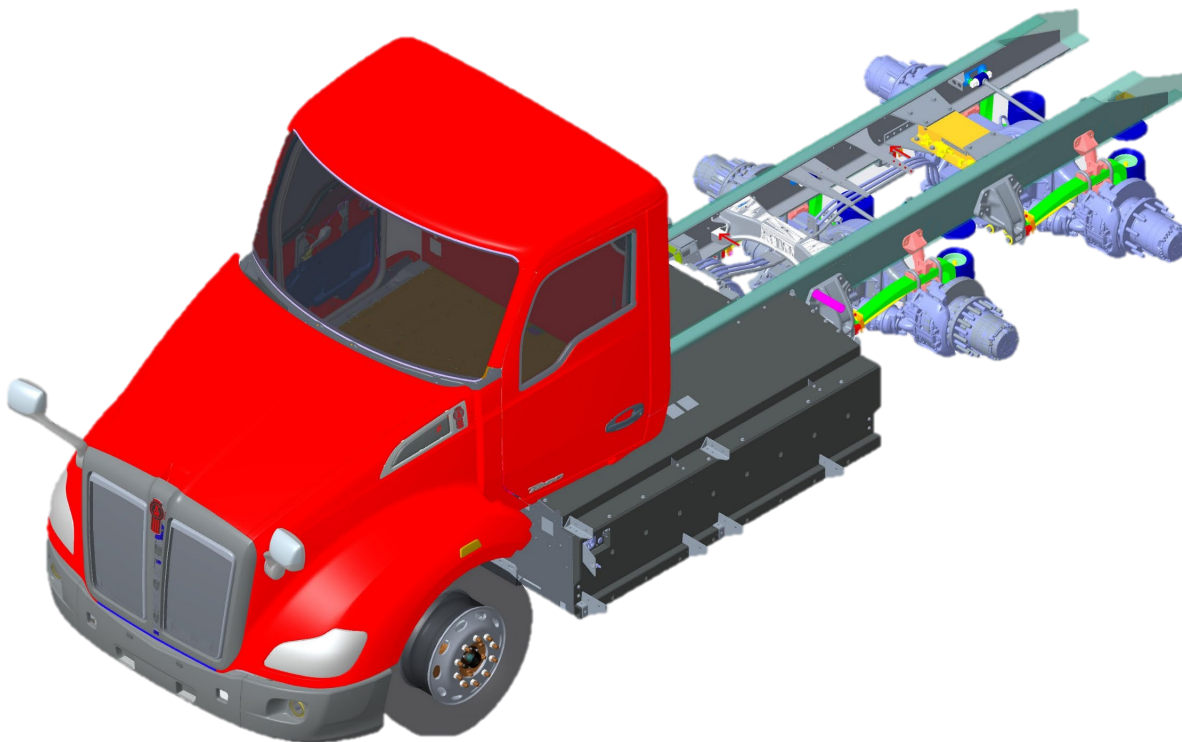

*Figure 5 T680E 190" Wheelbase*

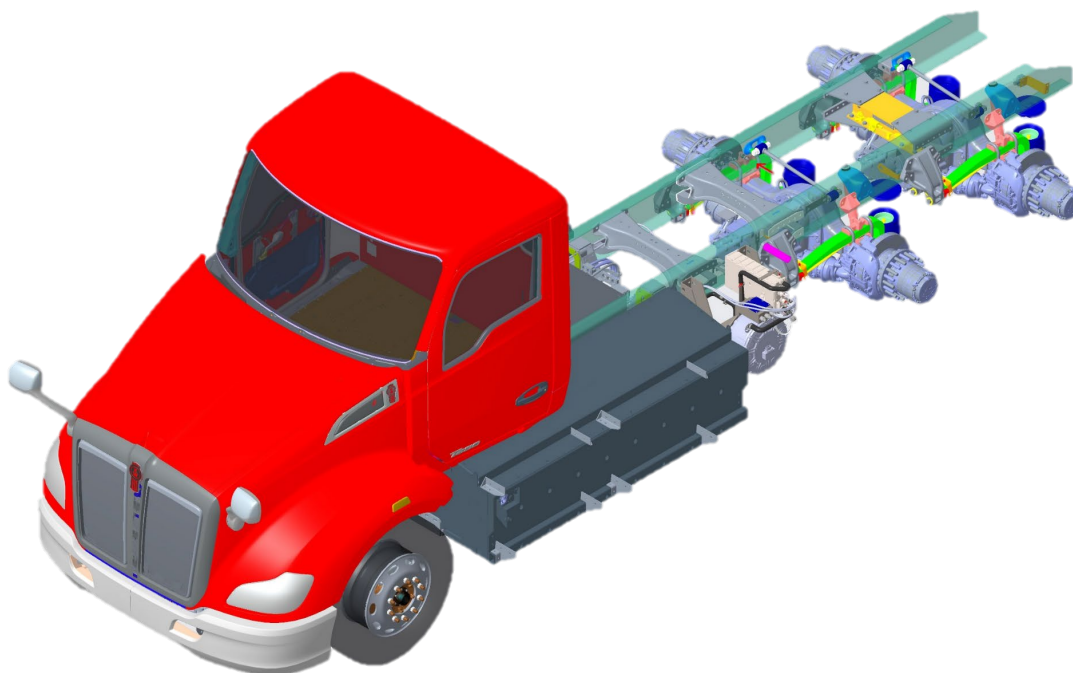
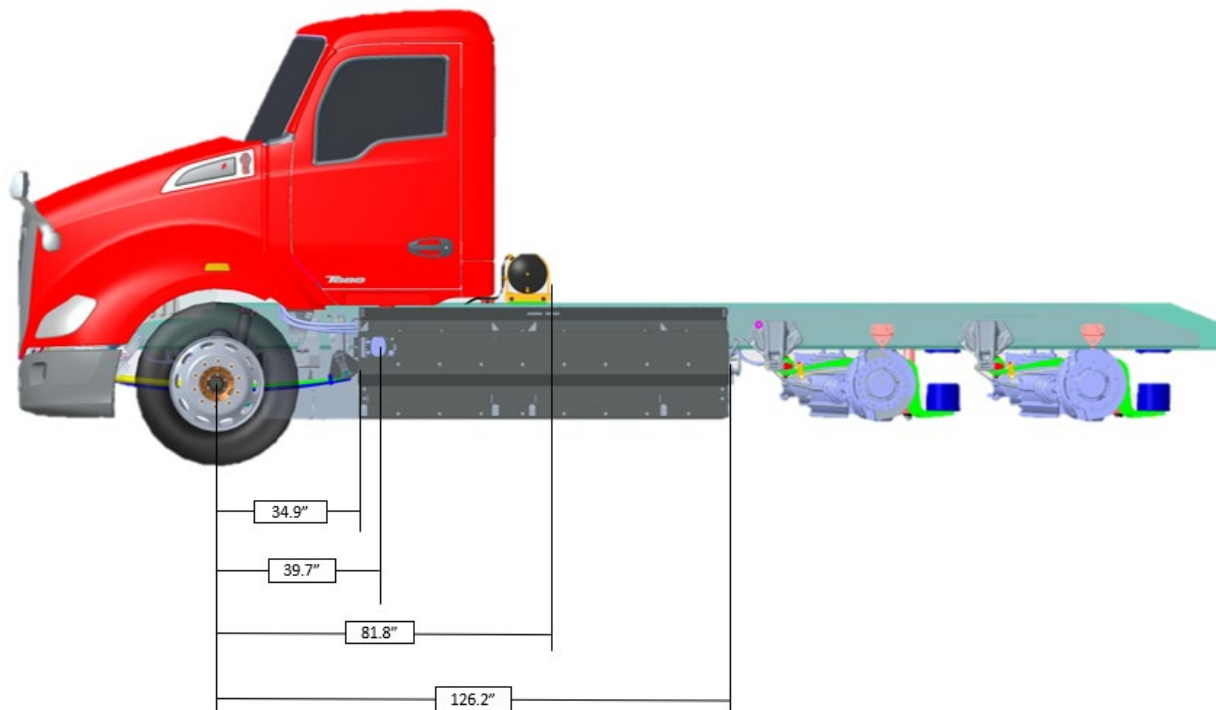

*Figure 6 T680E 216" Wheelbase*



*(shown with optional ePTO)*

## EXTERIOR DIMENSIONS



*Figure 7 T680E BEV Dimensions 190" WB*

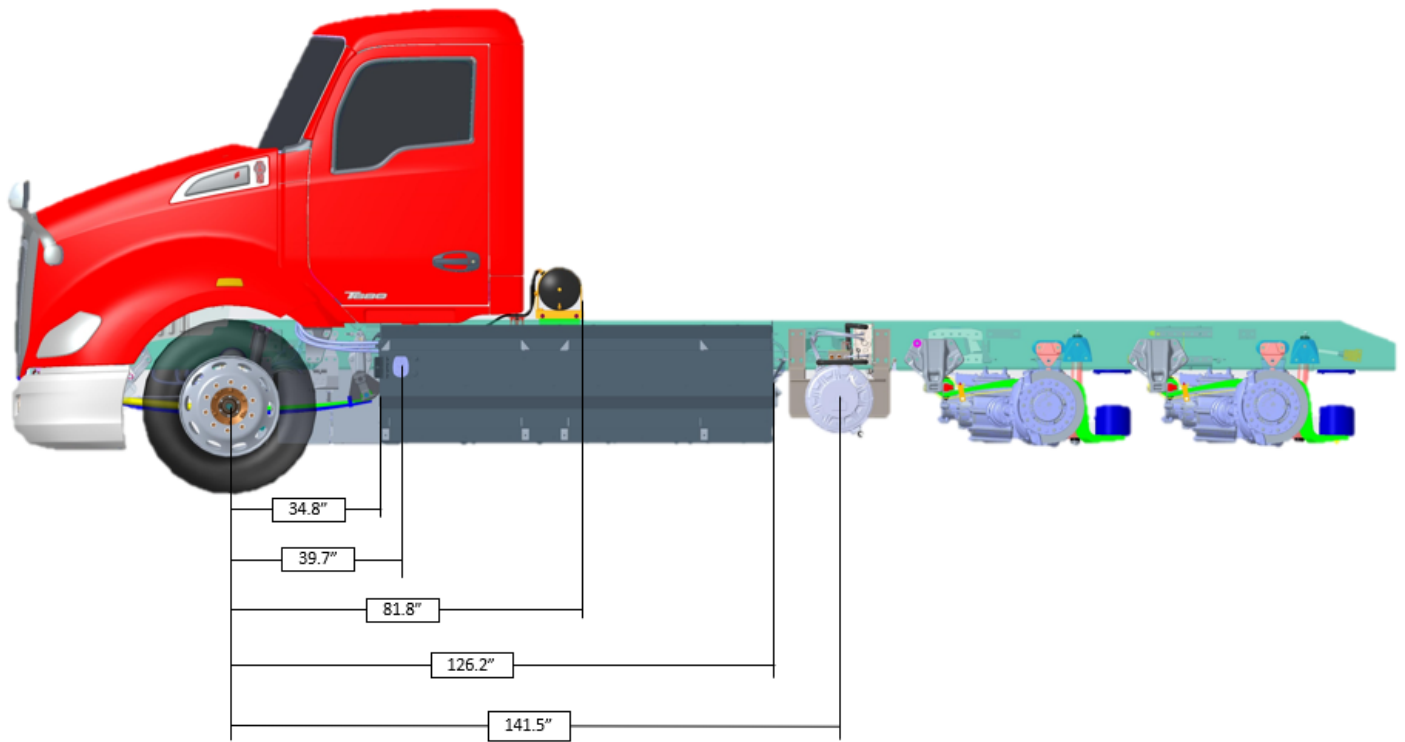

Figure 8 T680E Dimensions 216" (shown with optional ePTO)

### WHEELBASE CONFIGURATIONS

The T680E is available in two wheelbase configurations. The 190" wheelbase intended for non-ePTO configurations, and 216" to allow for a Left-hand frame mounted electric power take off (ePTO).

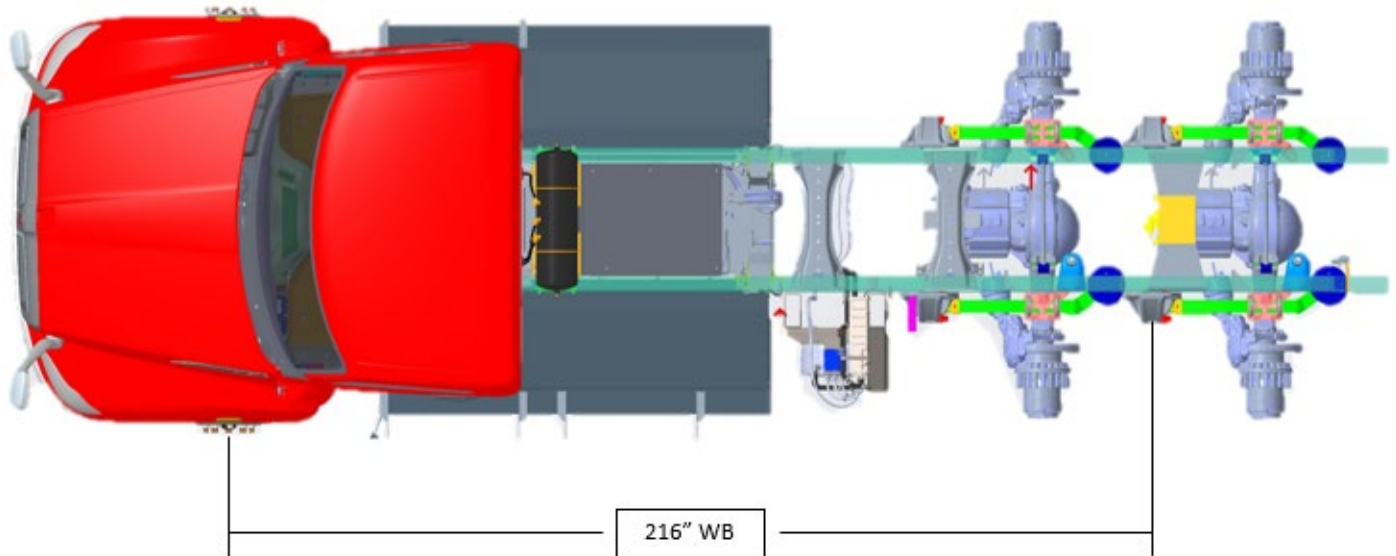
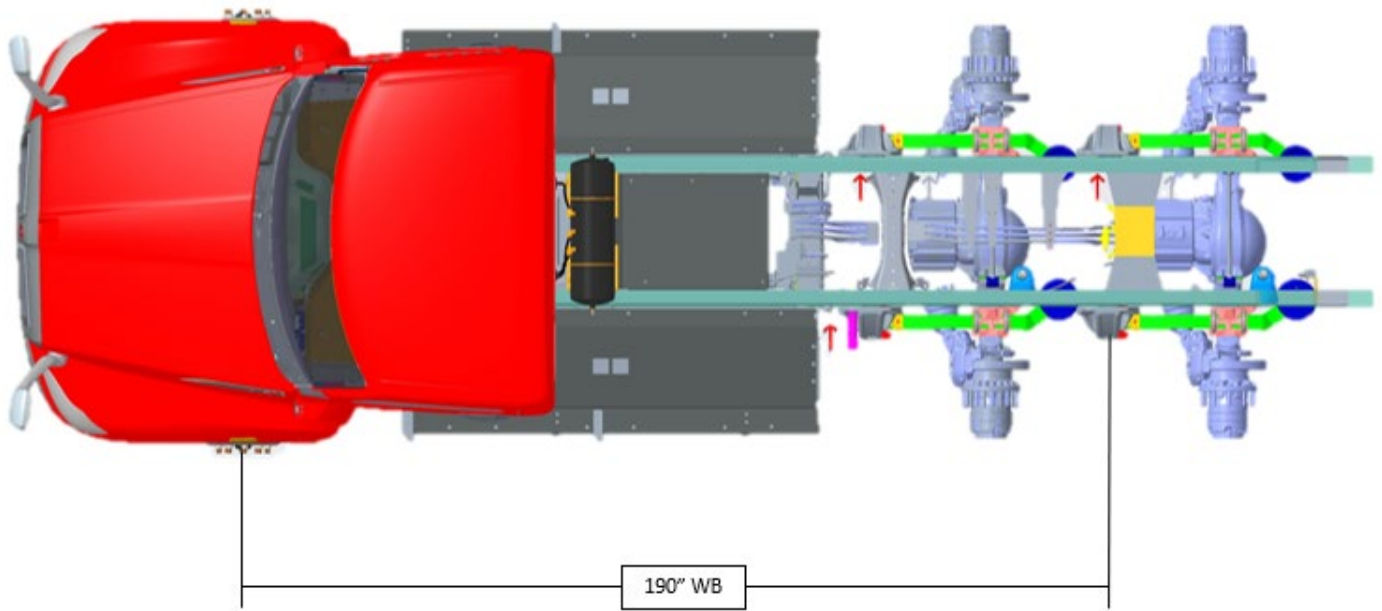

Figure 9 T680E BEV 216" Wheelbase (shown with optional ePTO)



*Figure 10 T680E BEV 190" Wheelbase*





# SECTION 4 - BODY MOUNTING

## INTRODUCTION

This section has been designed to provide supplemental information specific to the T680E to aid in body mounting. Refer to Kenworth Heavy Duty Body Builder Manual for additional information. This is not intended as a complete guide, but as general information. Body mounting strategies are unique to each body type, and body builders must determine the appropriate method.

### NOTE:



**Note: An alignment adjustment is required after body installation. Front alignment and rear alignment must be performed prior to putting the vehicle into service.**

Please contact your local Kenworth dealer if more information is desired.

Main Rail Height (in.)	Insert size	Combined Section Modulus (In. <sup>3</sup> )	Per Rail		Per Pair of Rail
			RBM (in.-lbs.)	Weight (lbs./in.)	Weight (lbs./in.)
11-5/8	10-3/4"	37.93	4,551,000	3.64	7.28

## CRITICAL CLEARANCES

### Tire Clearance

Normal suspension movement could cause contact between the tires and the body. To prevent this, mount the body so that the minimum clearance between the top of the tire and the bottom of the body is 8 inches (203 mm). This should be measured with the body empty. See Figure 11.

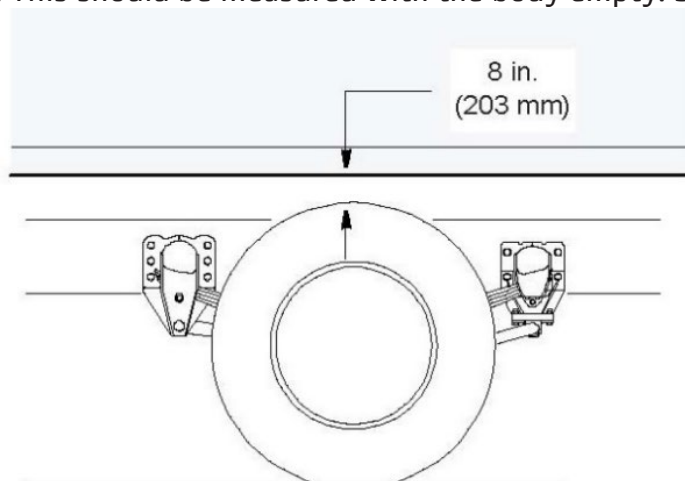

*Figure 11 Minimum Clearance between Top of Rear Tires and Body Structure Overhang*



**CAUTION:** Insufficient clearance between rear tires and body structure could cause damage to the body during suspension movement.

## FRAME DRILLING



**WARNING!** When mounting a body to the chassis, DO NOT drill holes in the upper or lower flange of the frame rail. If the frame rail flanges are modified or damaged, the rail could fail prematurely and cause an accident. Mount the body using body mounting brackets or U-bolts.

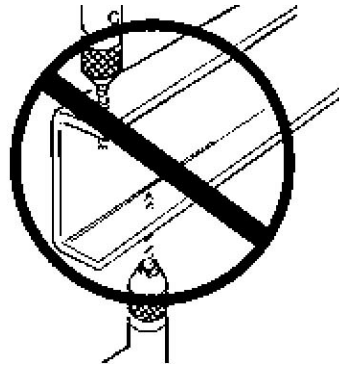

*Figure 12 Frame Rail Flange Drilling Prohibited*



**WARNING!** DO NOT drill closely spaced holes in the frame rail. Frame hole centers of two adjacent holes should be spaced no less than twice the diameter of the largest hole. Closer spacing could induce a failure between the two holes.



**CAUTION:** An appropriately sized bolt and nut must be installed and torqued properly in all unused frame holes. Failure to do so could result in a frame crack initiation around the hole.



**CAUTION:** Use care when drilling the frame web so the wires and air lines routed inside the rail are not damaged. Failure to do so could cause an inoperable electrical or air system circuit.



**CAUTION:** Never use a torch to make holes in the rail. Use the appropriate diameter drill bit. Heat from a torch will affect the material properties of the frame rail and could result in frame rail cracks.



**CAUTION:** The frame hole diameter should not exceed the bolt diameter by more than .060 inches (1.5mm)

## BODY MOUNTING USING U-BOLTS

If the body is mounted to the frame with U-bolts, use a hardwood sill (minimum 1/2 inch thick) between the frame rail and body frame to protect the top surface of the rail flange



**WARNING!** Do not allow the frame rails or flanges to deform when tightening the U-bolts. It will weaken the frame and could cause an accident. Use suitable spacers made of steel or hardwood on the inside of the frame rail to prevent collapse of the frame flanges.

Use a hardwood spacer between the bottom flange and the U-bolt to prevent the U-bolt from notching the frame flange. See Figure 13

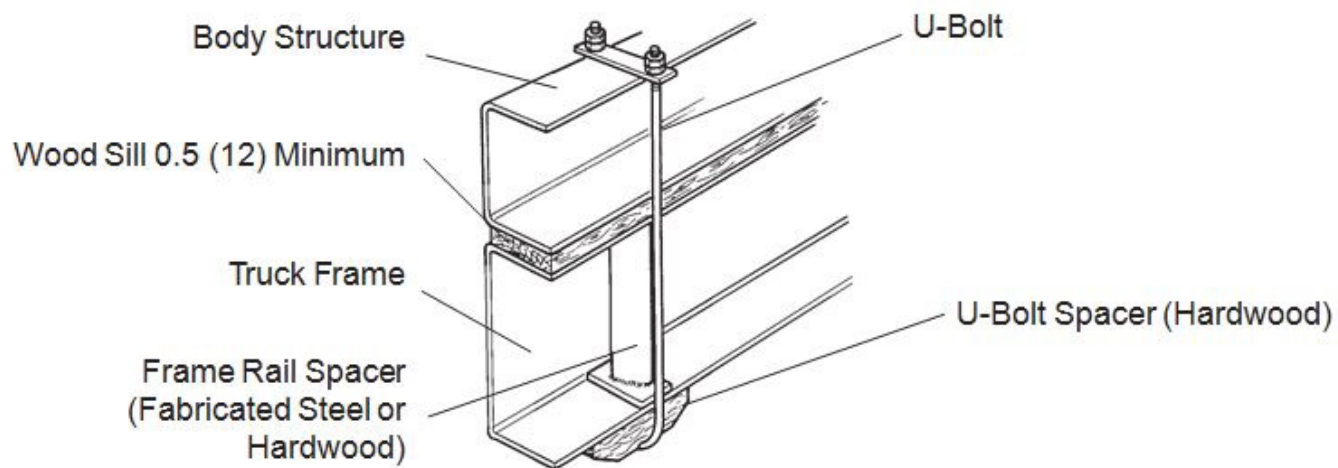

*Figure 13 Acceptable U-Bolt Mounting with Wood and Fabricated Spacers*



**WARNING!** Do not allow spacers and other body mounting parts to interfere with brake lines, fuel lines, or wiring harnesses routed inside the frame rail. Crimped or damaged brake lines, fuel lines, or wiring could result in loss of braking, fuel leaks, electrical overload, or a fire. Carefully inspect the installation to ensure adequate clearances for air brake lines, fuel lines, and wiring. See **Figure 14**.

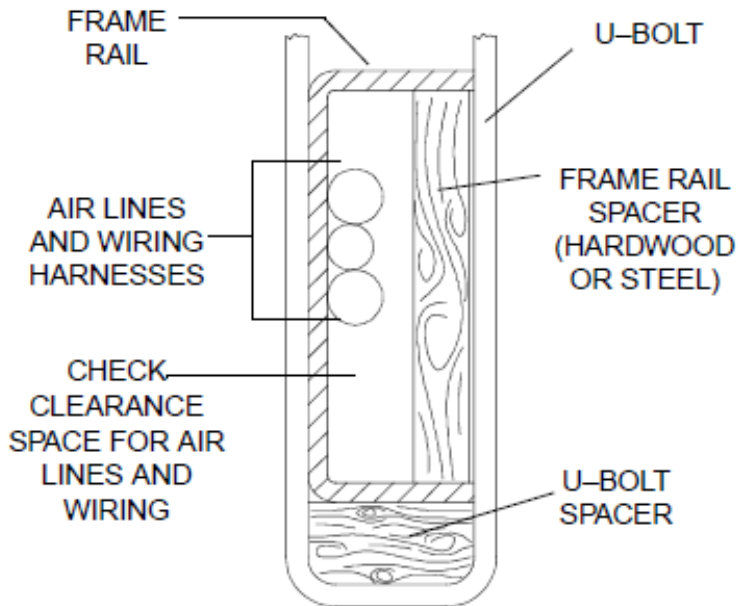

*Figure 14 Clearance Space for Air Lines and Cables*



**WARNING!** Do not notch frame rail flanges to force a U-bolt fit. Notched or damaged frame flanges could result in premature frame failure. Use a larger size U-bolt



**CAUTION:** Mount U-bolts so they do not chafe on frame rail, air, or electric lines.



## REAR BODY MOUNT

When U-bolts are used to mount a body, we recommend that the last body attachment be made with a “fishplate” bracket. See **Figure 15**. This provides a firm attachment point and helps prevent any relative fore or aft movement between the body and frame. For frame hole location guidelines, see Error! Reference source not found.

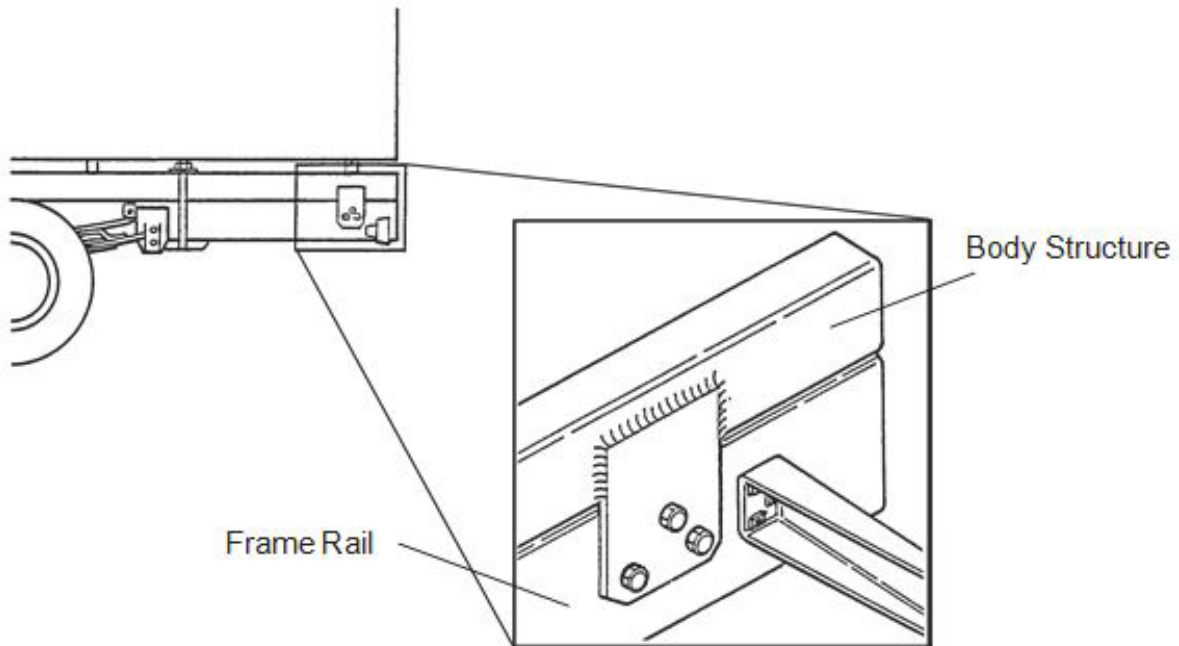

*Figure 15 Fishplate Bracket at Rear End of Body*



# SECTION 5 FRAME MODIFICATIONS

## INTRODUCTION

Kenworth offers the T680E in two wheelbase configurations; 190" and 216", changes to the wheelbase are not allowed

**Modification to T680E Battery Electric Vehicle frame is NOT recommended.**



***WARNING! Battery Electric Vehicle systems could be damaged by improper disconnection, disassembly, frame drilling, welding, use of a torch, or any frame modifications beyond attaching to the factory supplied Body Builder brackets. Systems could be permanently damaged and personal injury or death could occur. Contact your local Kenworth dealership for support and guidance for any frame modifications.***

---



# SECTION 6 – ELECTRICAL

## INTRODUCTION

The T680 E utilizes the pre-VMUX electrical architecture; the pre-VMUX information is in the Kenworth Heavy Duty Body Builder Manual 2017.



# SECTION 7 – electric POWER TAKE-OFF (ePTO)

## INTRODUCTION

An electric Power Take Off (ePTO) provides a way to divert battery electric power to another component.

## BATTERY ELECTRIC VEHICLE ePTO POWER SOURCE

On the Power Distribution Unit, the rearward facing surface of this component has the Power Source interface plug (orange plug below). This allows access to the High Voltage (HV) system for ancillary components or the optional ePTO discussed in the next paragraph. See the Meritor Blue Horizon Electric Power Take Off System Interface Control Document for additional information including the parameters of this HV plug, including relevant safety and handling disclosures.

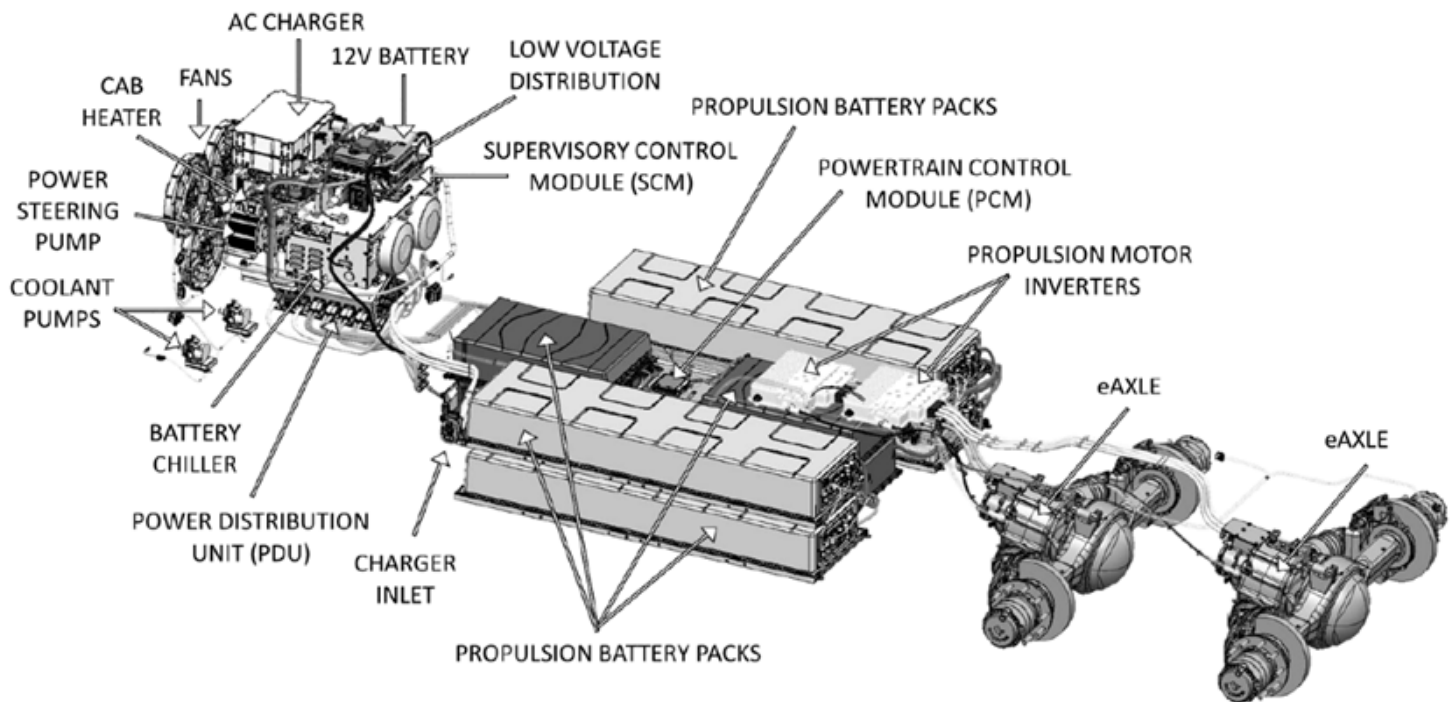

Figure 16 T680E Layout







## BATTERY ELECTRIC VEHICLE ePTO

The Battery Electric Model T680E is available in two wheelbase configurations. The 190" wheelbase intended for non-ePTO configurations, and 216" is the only configuration offered to support installation of a Left-hand frame mounted electric power take off (ePTO).

The ePTO system includes a mechanical splined interface to operate aftermarket equipment such as a hydraulic pump. Details of the mounting and spline size below.

See the Meritor Blue Horizon Electric Power Take Off System Interface Control Document for additional ePTO information.

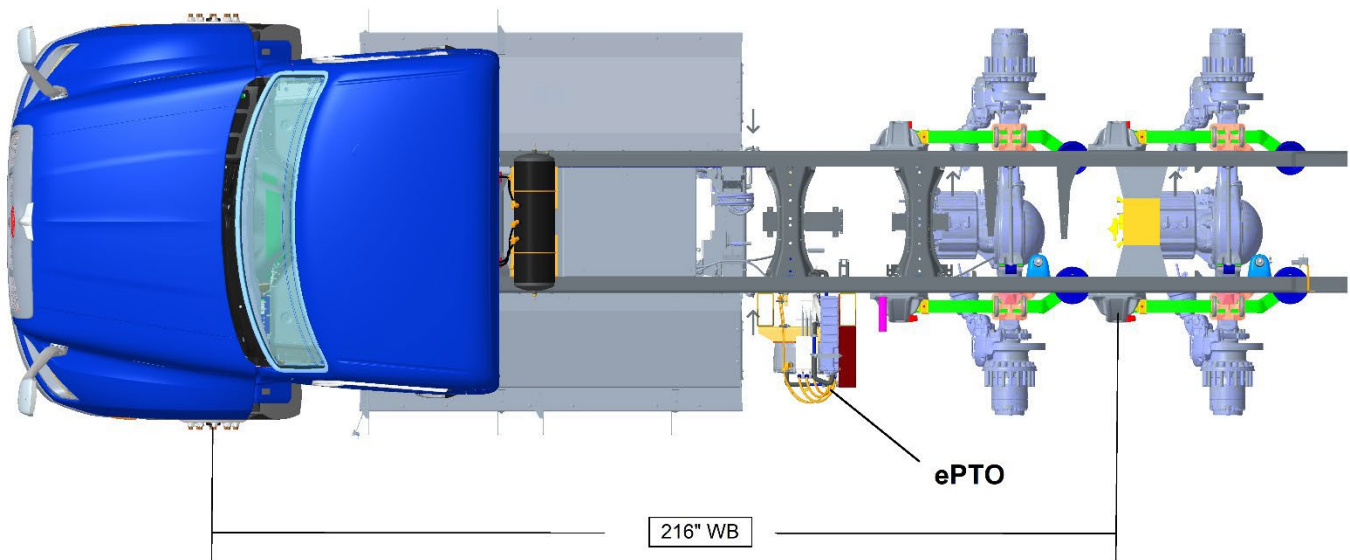

*Figure 17 Model T680 BEV with ePTO mount*

The Meritor ePTO is shown below in Figure 18. The Body Builder will attach to the splined coupling on the backside of the ePTO. Mounting surface details in Figure 20 and coupler details in Figure 21 below.

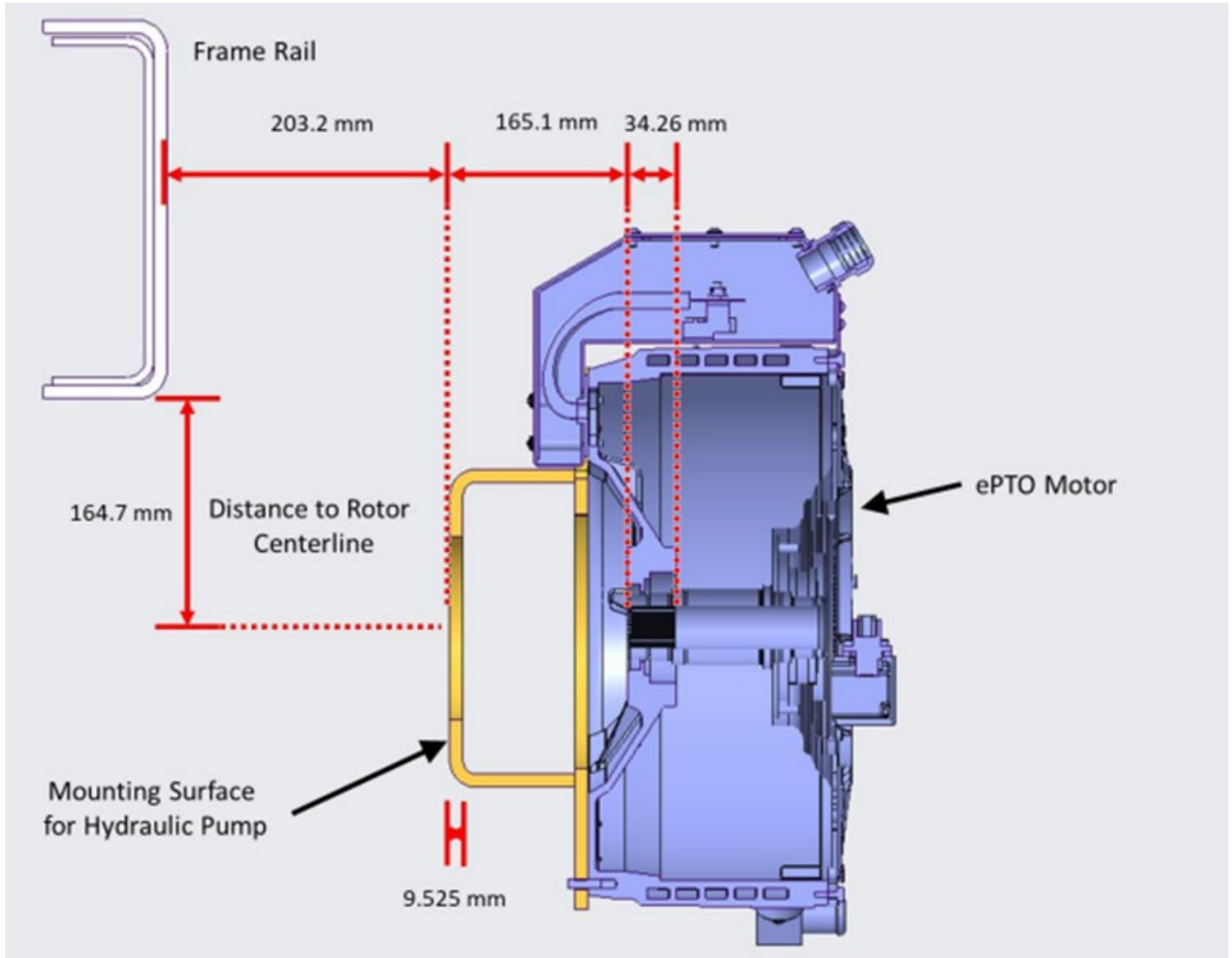

Figure 18 Meritor ePTO Dimensions



EXTERNAL INVOLUTE SPLINE, MOTOR FLAT ROOT SIDE FIT		
UNITS	IMPERIAL	METRIC
SPECIFICATION	B-92.1	
SPLINE	INPUT	
NUMBER OF TEETH	27	
SPLINE PITCH	24/48	
PRESSURE ANGLE	30°	
BASE DIAMETER (REF)	0.9742786	24.747
PITCH DIAMETER (REF)	1.125000	28.575
MAJOR DIAMETER	1.167	29.642
MINOR DIAMETER	1.055	26.797
FORM DIAMETER	1.079	27.407
TOOTH THICKNESS		
MAX EFFECTIVE	0.0654	1.661
MIN ACTUAL	0.0627	1.593

*Figure 19 Meritor Rotor Specifications*

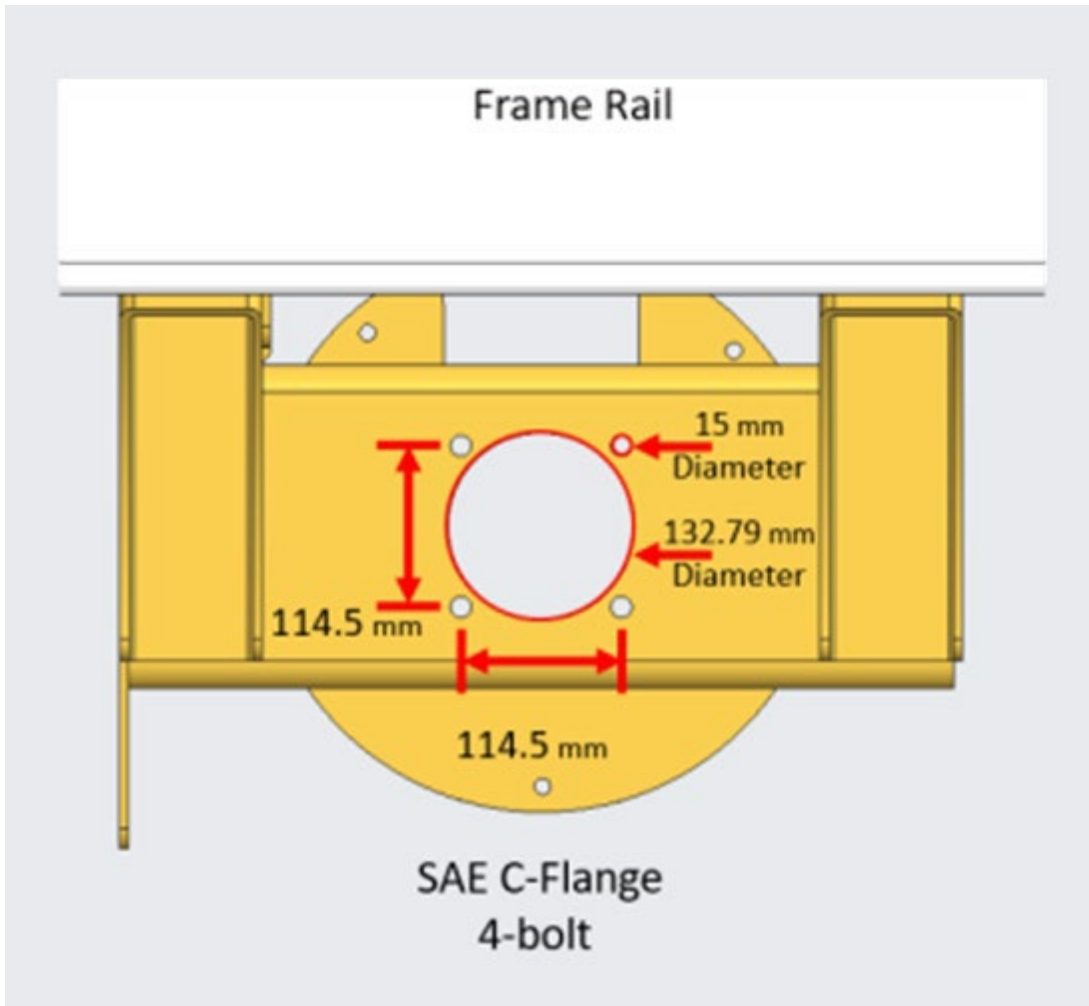

Figure 20 Mounting Surface for Hydraulic Pump (View from underneath frame looking outward to backside of ePTO)



Figure 21 Keyway Coupling (Reference McMaster 61005K188 shown; Body Builder supplied)



# Appendix

## VEHICLE IDENTIFICATION

A 17-character number (numeral and letter combination) forms the Vehicle Identification Number (VIN) which includes the Chassis Number. It contains, among other information, the model year (4), assembly plant (5), and vehicle serial number (6). **Figure 22**

The model year (4) is designated by an alphanumeric code in the tenth character position in the VIN. See **Table 2** and **Figure 23**.

SAMPLE VIN

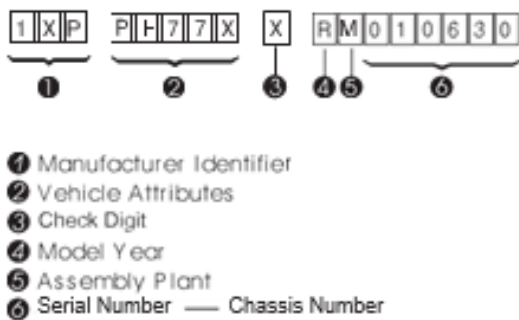

Table 2 Model Year (Code) Designation

Code	Year
5	2005
6	2006
7	2007
8	2008
9	2009
A	2010
B	2011
C	2012
D	2013
E	2014
F	2015
G	2016
H	2017
J	2018
K	2019
L	2020
M	2021
N	2022
P	2023
R	2024

Figure 22 Vehicle Identification Number (VIN)

### VIN Location

The VIN is marked on the Incomplete Vehicle Certification Label (on trucks). It is located either on the driver’s door edge or door frame. See **Figure 23**.

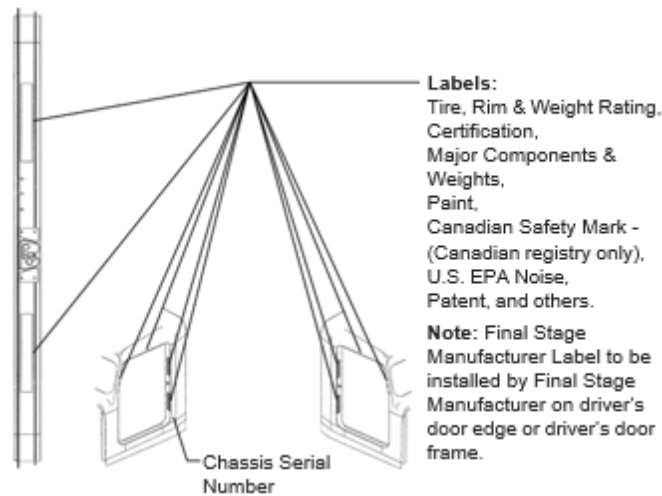

*Figure 23 VIN Label Locations*

### Chassis Number Locations

The Chassis Number comprises the last six characters of the VIN and is shown in multiple locations on the vehicle.

- Left side of cab, back wall of cab: stamped plate. (Daycab)
- Tire, Rim, and Weight Rating Data label.
- Major Components and Weights label.
- Noise Emission label.
- Paint Identification label.

### VEHICLE IDENTIFICATION LABELS

Vehicle Identification Labels are located on the driver's side door edge or on either the driver's or passenger's side door frames. See Figure 23 Labels include Vehicle Certification, Components and Weights, Tire/Rim and Weight Rating Data, Noise Emissions, and Paint Identification. Quantity and location of labels may differ based on Complete/Incomplete vehicle, and Single/Dual certification.

### Tire and Rim Weight Rating Data Label

The Tire and Rim Weight Rating Data Label is used in conjunction with the Incomplete Vehicle Certification Label on Incomplete Vehicles. It contains the chassis serial number and the following information:

- GVWR — Gross Vehicle Weight Rating
- GAWR FRONT and REAR — Gross Axle Weight Ratings for Front and Rear Axle
- TIRE/RIM SIZES AND INFLATION PRESSURES — Tire/Rim Sizes and Cold Pressure Minimums

#### **NOTE:**



GVWR is the TOTAL WEIGHT the vehicle is designed to carry. This includes the weight of the empty vehicle, loading platform, occupants, fuel, and any load.

### Incomplete Vehicle Certification Label



The Incomplete Vehicle Certification Label contains the chassis VIN, date of manufacture, and listing of applicable motor vehicle safety standards.

### **Components and Weights Label**

The Major Components and Weights Label includes chassis weight and gross weight information, as well as model and serial numbers for the vehicle, engine, transmission, and axles.

### **Noise Emission Label**

The Noise Emission Label contains the chassis serial number, date of manufacture, and information regarding US noise emission regulations. This label is not provided on Canadian registered vehicles.

### **Paint Identification Label**

The Paint Identification Label contains the paint colors used by the factory to paint the truck. It lists frame, wheels, cab interior and exterior colors. This label is located either underneath the dash to the left of the steering column support, inside the glovebox, or on the passenger's door frame.

## **COMPONENT IDENTIFICATION**

Each of the following components has their own identification label.

### **Transmission Identification**

The transmission identification number is stamped on a tag affixed to the right forward side of the transmission case. It includes the transmission model, serial, and part number among other specifications.

### **Front Axle Identification**

The front axle has an identification tag located on the front axle beam. It includes the axle model, part number and serial number.

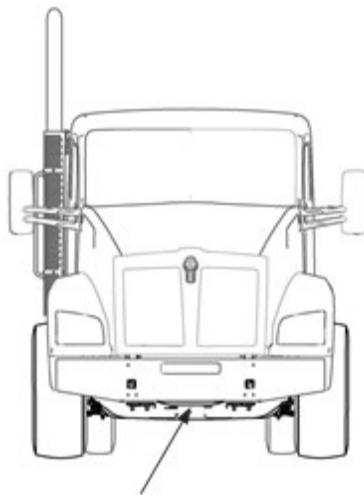

*Figure 24 Front Axle Identification*

### **Rear Axle Identification**



The rear axle identification numbering system includes two labels or stamps.

1. **Axle Housing Number Tag** located on the left forward side of the housing arm. This tag identifies the axle housing.
2. **Axle Differential Carrier Identification** located on the top side of the differential carrier. The following information is either stamped, or marked with a metal tag: Model No., Carrier Production Assembly No., Carrier Assembly Serial No., Gear Ratio, Axle Specifications Number and OEM part number and country of origin.

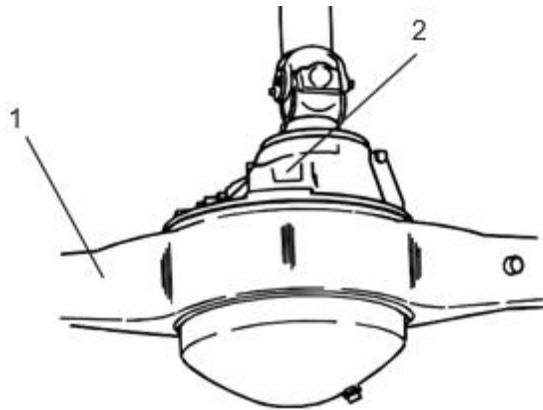

*Figure 25 Rear Axle Identification*

**NOTE:**



Illustrated identification tag locations are typical. Actual locations may vary by axle manufacturer and with single versus tandem axles.





# Table of Figures

Figure 1 Incomplete Vehicle Certification Document .....	6
Figure 2 Locations of Certification Labels - Driver’s Door and Frame.....	7
Figure 3 Vehicle Layout.....	9
Figure 4 Additional Components on the PCAS (PCAS: Power Electronics and Controls System).....	10
Figure 5 T680E 190” Wheelbase .....	12
Figure 6 T680E 216” Wheelbase .....	12
Figure 7 T680E BEV Dimensions 190” WB.....	13
Figure 8 T680E Dimensions 216” (shown with optional ePTO).....	14
Figure 9 T680E BEV 216” Wheelbase (shown with optional ePTO) .....	14
Figure 10 T680E BEV 190” Wheelbase.....	15
Figure 11 Minimum Clearance between Top of Rear Tires and Body Structure Overhang.....	16
Figure 12 Frame Rail Flange Drilling Prohibited.....	17
Figure 13 Acceptable U-Bolt Mounting with Wood and Fabricated Spacers .....	18
Figure 14 Clearance Space for Air Lines and Cables .....	19
Figure 15 Fishplate Bracket at Rear End of Body .....	20
Figure 16 T680E Layout .....	23
Figure 17 Model T680 BEV with ePTO mount.....	24
Figure 18 Meritor ePTO Dimensions.....	25
Figure 19 Meritor Rotor Specifications .....	26
Figure 20 Mounting Surface for Hydraulic Pump (View from underneath frame looking outward to backside of ePTO).....	27
Figure 21 Keyway Coupling (Reference McMaster 61005K188 shown; Body Builder supplied) .....	27
Figure 22 Vehicle Identification Number (VIN).....	28
Figure 23 VIN Label Locations .....	29
Figure 24 Front Axle Identification.....	30
Figure 25 Rear Axle Identification.....	31



# Table of Tables

Table 1 Abbreviations Used ..... 11  
Table 2 Model Year (Code) Designation ..... 28

## Revision Log

Revision Log – T680E Builder Manual				